

Sheeter 568

for in-line Signature Fold

PACIFIC
series

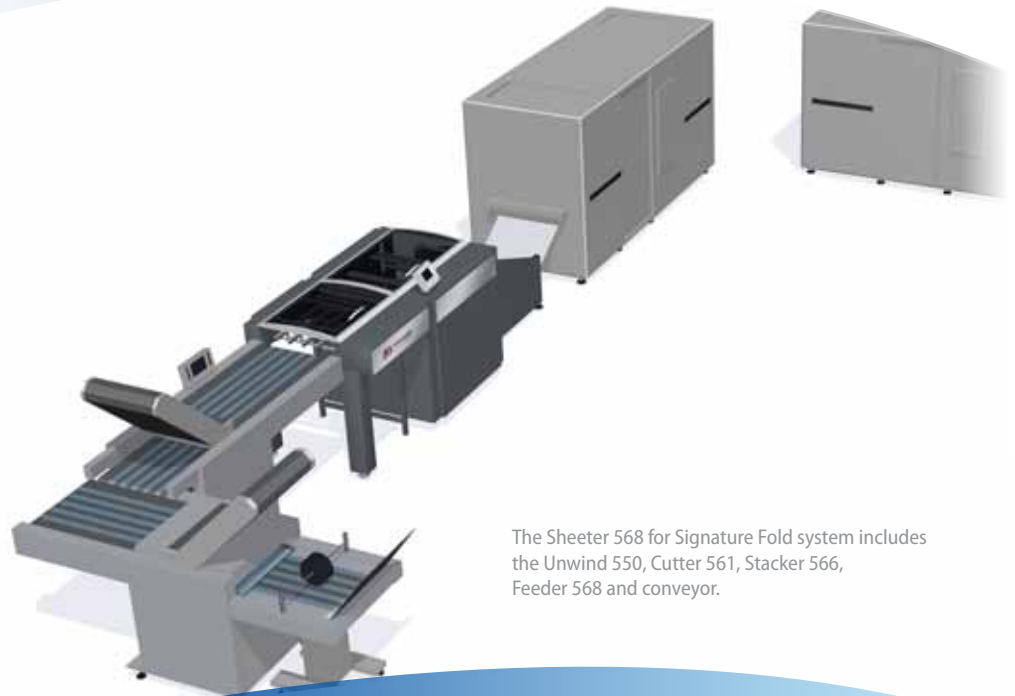

The Sheeter 568 for Signature Fold system includes the Unwind 550, Cutter 561, Stacker 566, Feeder 568 and conveyor.

- Signatures created in-line
- Lightweight compatible
- Flexible operation
- Easy application changes

In-line signature folds, and more

Prepare book signatures quickly and easily in-line with your digital web printer. The Pacific series Sheeter 568 system with in-line signature folder effortlessly produces folded forms or signatures for print on demand applications including short-run books and stitched booklets, as well as for direct mail.

The Sheeter 568 system precisely cuts and delivers sheets as light as 11# bond or 40 gsm to an in-line folder, for signatures of up to 32 pages. Off-line labor is reduced, and jobs are completed sooner. Not only does this system create superior

folded signatures, the bypass function makes it easy to alternate from cut and stacked to folded applications, providing the flexibility critical to your operation.

As with all of our products, the Pacific series Sheeter 568 system is compatible with today's most advanced digital printers and can be adapted to meet your printing needs. Innovative products combined with award winning support and service make Lasermax Roll Systems the essential partner for your print operation.

Sheeter 568

for in-line Signature Fold

The Pacific series Sheeter 568 system for in-line signature fold features the Unwind 550, Cutter 561 and Stacker 566, Feeder 568 and conveyor operating with a third-party folder to produce multi-folded signatures in-line.

The center-shaft driven Unwind 550 feeds a roll of paper up to 20.5" wide and 52" in diameter into the printer for continuous printing. Once the paper is printed, the Cutter 561 uses a rotary knife to cut printed output to the desired length.

Individual sheets are then bypassed through the Stacker 566 and the Feeder 568 squares the sheets and delivers them to the folder. The sheets are folded to create signatures with up to 32 pages, depending on the folder configuration. Signatures can then be gathered into sets for near-line binding. The Sheeter 568 system is an ideal method for perfect-bound books requiring lightweight paper.

For stacked cut sheet book blocks, the Stacker 566 builds 8.5" stacks of sheets. Using the most advanced technology available, stacks created with the Sheeter 568 system are clean and

tightly trimmed. Once paper is accurately cut and stacked, each set can be delivered to the conveyor one at a time, individually offset within the stack or when the operator-programmed stack height is reached. Book blocks can then be easily transported to near-line finishing units, such as Binders or Stickers.

Output delivery options are easily switched with no movement of modules, to offer the flexibility you need for your print on demand applications. All components are modular, compact, and are designed to dramatically improve workflow.

Optional Capabilities

Lightweight Paper

For lightweight paper applications, add the optional Buffer 530 to the Sheeter 568 system. Positioned between the printer and the Cutter 561, the Buffer 530 accumulates the lightweight paper web and weaves it through rollers that rise and fall, filling the buffer and allowing job delivery without stopping the printer.

Slit Merge

The Merger 535 option allows a 2-up printed web to be slit and merged into a single, collated paper stream. Positioned between the printer and the Cutter 561*, the web enters the Merger 535 and is slit in the center. A sensor continuously monitors the web for side-to-side variations or movement and the slitter automatically adjusts to cut precisely at the center of the web. The



Merger 535

resulting two webs are then merged right-over-left or left-over-right, depending on the requirements of the application.

*Pinless slit merge applications require the Cutter 562.

Cutter 562

Same features as the Cutter 561, plus the ability to process pinless slit merge applications.

Specifications

Performance / Media-Stacking

Speed Max.	450 ft/min	2.25 m/sec
Print	Simplex, Duplex	
Feeding	Pinfed or pinless	
Paper weight	11# bond-110# index	40-200 gsm <small>(Testing mandatory for paper less than 55 gsm)</small>
Roll diameter	4"-52"	100 mm-1320 mm
Web width	5.5"-20.5"	140 mm-520 mm
Form length		
Stacks	3.5"-19.5"	90 mm-495 mm
Signatures	48"	1220 mm
Stack Height	Max. 8.5"	216 mm
Offset	0.6"	15 mm
Output options	1-, 2-, 3-up with offset	

Electrical

Power	208 VAC, 1 Phase, 15A, or 200-240 VAC 50/60 Hz, 10A
--------------	--

Configuration Example

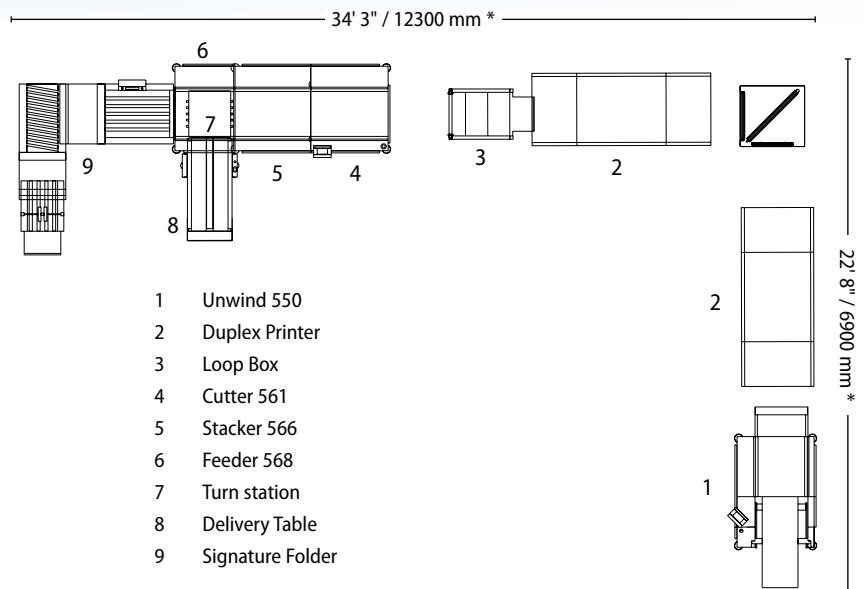

*Length will vary by printer model.

050510

©2010 Lasermax Roll Systems. All rights reserved. The LR symbol and LASERMAX ROLL SYSTEMS are registered trademarks and WebVision is a trademark of Lasermax Roll Systems. We reserve the right to make any technical amendments without prior notification.



www.lasermaxroll.com

China	Shanghai	+86 216 2790792	info@lasermaxrollsystems.cn
	Beijing	+86 108 5804932	info@lasermaxrollsystems.cn
Singapore		+65 6793 9478	info@lasermaxroll.sg
Sweden		+46 372 256 00	info@lasermaxroll.se
United Kingdom		+44 179 370 7110	info@lasermaxroll.co.uk
USA		+1 781 229 2266	info@lasermaxroll.com